



OFFICINE MARIO DORIN SINCE 1918

**DORIN**<sup>®</sup>  
INNOVATION



## HEX 系列

SEMI-HERMETIC MOTOR COMPRESSORS ATEX CERTIFIED

HC/HFC/HFO APPLICATION - 50/60 Hz

ATEX认证半封闭防爆压缩机系列

HC/HFC/HFO应用- 50/60 Hz





## DORIN Web Software

都凌 (在线) 选型软件

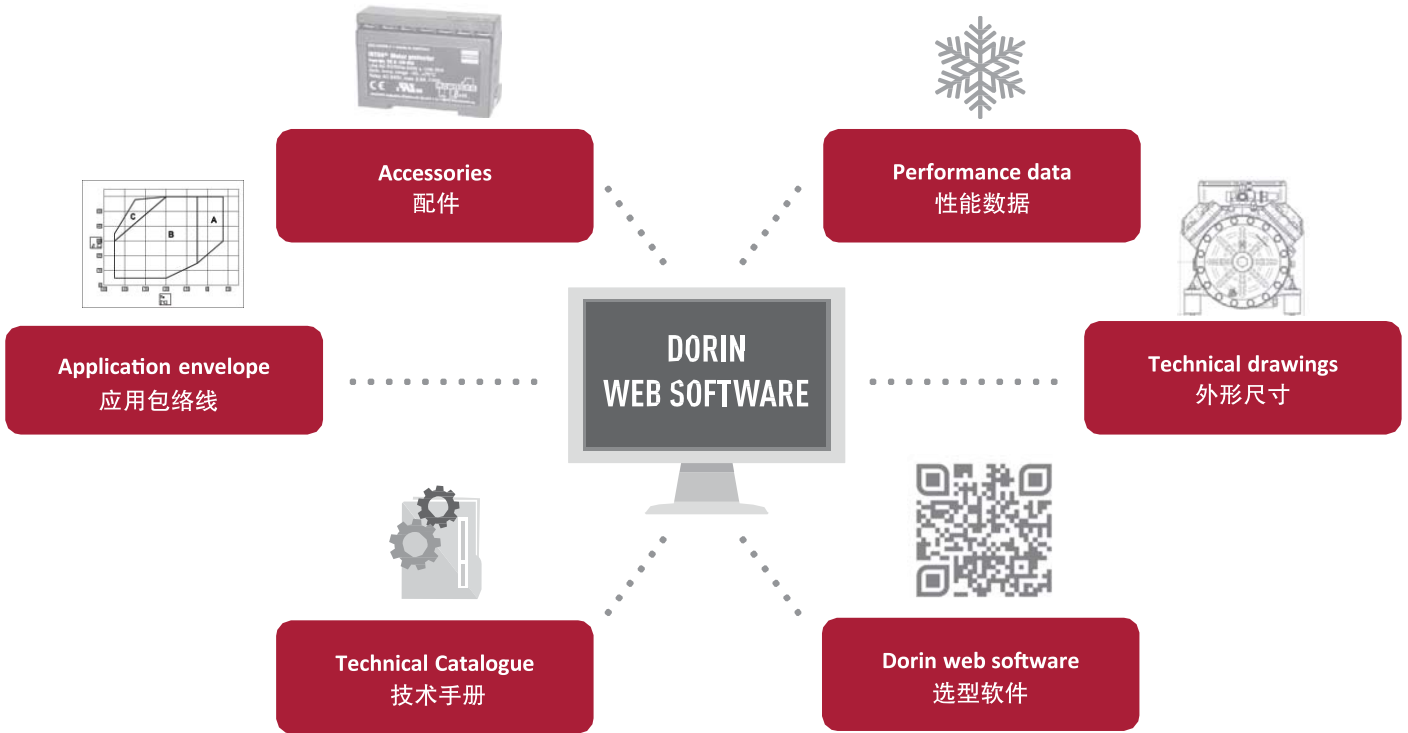

## Frequency Range

频率范围

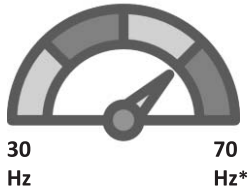

\* Maximum operating frequency to be checked in the dedicated technical bulletin

\* 最大运行频率须参阅专门的技术手册

## Refrigerants in DORIN software (GWP - AR4)

制冷剂参照选型软件

	SAFETY GROUP A1 安全组别A1				SAFETY GROUP A2L 安全组别A2L	SAFETY GROUP A3 安全组别A3
LT - MT	R404A (3922)	R507A (3985)	R448A (1387)	R449A (1397)	R454C (148)	R290 (3)
	R22 (1810)	R407F (1810)	R407A (1825)	R452A (2140)	R455A (148)	R1270 (2)
MT - HT	R134A (1430)	R513A (631)	R450A (604)	R407C (1774)		

For all the refrigerants not available in the software please contact DORIN for the calculations

对于选型软件未涉及的制冷剂，请联系Dorin都凌技术人员获得相关性能数据。

## Factory certifications

都凌工厂认证

ISO 45001:2018

ISO 9001:2015



## Compressor certifications

都凌压缩机认证

## HEX SERIES Features

### HEX系列产品特点



#### Silent operations and low vibrations

运行安静流畅，振动水平低

#### Crankshafts balanced individually, excellent fluid dynamics studies are our strengths

曲轴能够独立平衡运转，这得益于我们出色的流体动力学研究



#### All models VFD compatible

所有型号可变频运行

#### Bore / Stroke values and motors with extra tolerance to high temperature allow wide frequency ranges

电机、缸径、行程的优化配比使之可以实现宽频运行



#### Highest levels of efficiency

优异的运行效率

#### Using latest coating technologies for reducing frictions and improving lubrication

采用最新的涂层技术来减少摩擦和改善润滑



#### Patented oil containment system for extra low oil carry-over for models with oil pump

专利认证的油气分离系统，可显著降低带油泵型号的带油率

#### Higher system efficiency, less oil injections from the oil-separator for higher oil viscosity in the compressor sump

更高的系统效率。油分离器中的润滑油量大幅减少，压缩机中油的粘度得以提高



#### 2 years standard warranty

两年标准质保



#### ATEX Certification II 3G Ex ec h IIB T3 Gc

获得 ATEX II 3G Ex ec h IIB T3 Gc 认证



#### All compressors suitable for HC & HFC & HFO

所有HEX型号均适用于HC-HFC-HFO



#### Salt spray resistance test, certified for 1000 hours (NSS test in accordance with UNI EN ISO 4628, parts 2,3,8- Assessment method : UNI EN ISO 9227

耐盐雾1000小时测试，认证（NSS测试符合UNI EN ISO 4628，第2、3、8部分-评估方法：UNI EN ISO 9227）



#### Small foot print and reduced gross weight

轻量化和紧凑的设计

#### Optimized displacement values for crankcase size

根据曲轴箱大小对应的最优排量

## HEX SERIES Technical Features Features

### HEX系列产品特点

- 1** Extra reliability and efficiency of optimised valve plate design  
最优化的阀板设计保证可靠性和效率
- 2** IP65 junction box  
防护等级IP65的电气接线盒
- 3** Forced lubrication up to the wrist pin for the models with oil pump  
带油泵的型号，强制润滑到活塞销
- 4** Proven reliability of the electric motor thanks to the unique resistance to high temperatures  
由于独特的耐高温设计，电机的可靠性得到了保障
- 5** Crankcase heater and maximum discharge temperature sensor as standard accessories  
标配曲轴箱加热器和最高排气温度传感器

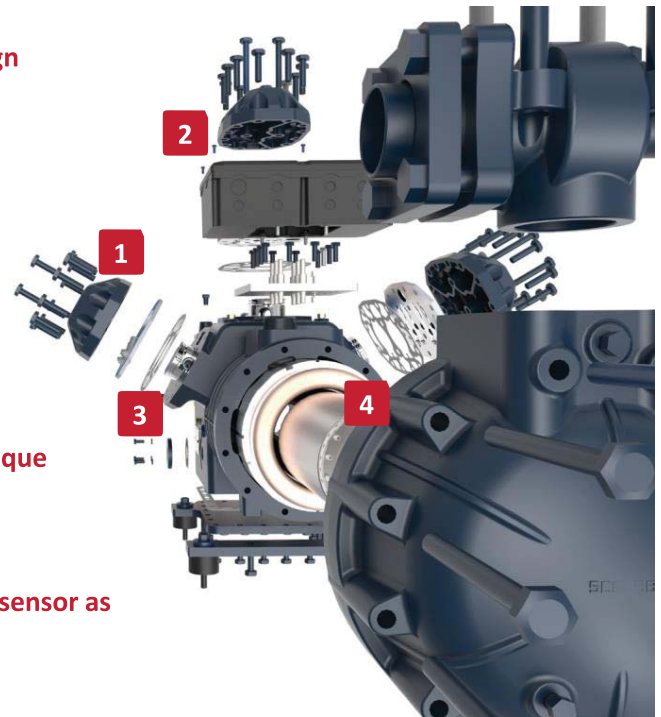

## HEX range - Displacement

### HEX系列 - 排量

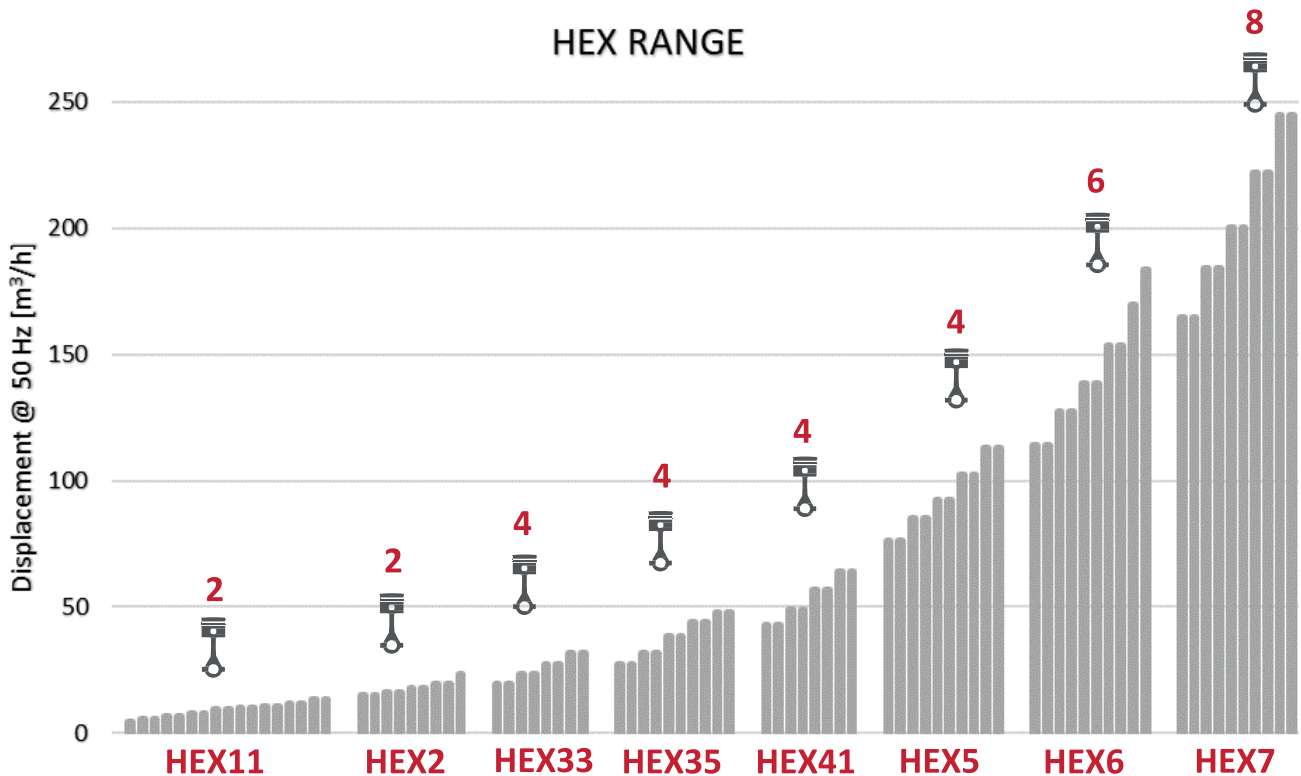

**THE WIDEST COMPRESSOR RANG IN THE MARKET**  
**FROM 4,42m³/h TO 244,78m³/h@50Hz**  
**FROM 0,5 TO 90 HORSE POWER**  
**市面上最广的压缩机排量 从4.42 m3/h到244.78 m3/h @ 50 Hz**  
**从0.5到90 Hp**

## Model name

### 型号命名

	VALID FOR 适用于以下制冷剂 R134a / R450A / R513A / R1234ze	VALID FOR ALL THE OTHER REFRIGERANTS 适用于其它制冷剂
<b>HEX101</b>	<b>C</b>	<b>C</b>
MODEL 型号	C   HIGH-MEDIUM-LOW EVAPORATING TEMPERATURE C   低-中-高蒸发温度	
	S   MEDIUM-LOW EVAPORATING TEMPERATURE S   中-低蒸发温度	
	B   LOW EVAPORATING TEMPERATURE B   低蒸发温度	

## ATEX Certification

### ATEX认证



Compressors belonging to HEX range are designed according to the safety requirements imposed for the use in flammable risky areas (zone 2, gas group IIB), as defined in ATEX 2014/34/EU. It is mandatory to carefully read instruction manual before compressor installation.

HEX 系列压缩机是根据 ATEX 2014/34/EU 中定义的易燃危险区域（区域 2，气体组 IIB）的安全要求设计的。安装压缩机前必须仔细阅读使用说明书。

## Application HEX SERIES

### HEX系列应用领域



**Industrial Refrigeration**  
工业制冷



**Heat pump**  
热泵应用



**Commercial Refrigeration**  
商超制冷

## Standard and Optional Accessories

### 标配件和选配件

		MODEL 型号							
● STANDARD 标配   ○ OPTIONAL 选配		HEX11	HEX2	HEX33	HEX35	HEX41	HEX5	HEX6	HEX7
	<b>Motor Protection (MT)</b> 电机保护 (MT)								
	Compressors are equipped with a PTC probe installed on every motor winding set at 120°C, combined with electronic protection module (REL) 压缩机的每个电机绕组都装有一个PTC探头, 设定在120°C与电机保护模块合并。	●	●	●	●	●	●	●	●
	<b>Electronic Protection Module (REL)</b> 电子保护模块 (REL)								
	Keeping under constant control winding temperature and discharge temperature / 确保电机绕组温度和压缩机排气温度在允许温度内	●	●	●	●	●	●	●	●
	<b>Crankcase Heater (CH)</b> 曲轴箱加热器 (CH)								
	The heater is 100 W up to HEX41 included and 200 W for HEX5/HEX6/HEX7 series(BT001)/ HEX41及以下系列加热器的功率为100W, HEX5 / HEX6 / HEX7 系列加热器的功率为200W。(参见技术手册BT001)	●	●	●	●	●	●	●	●
	<b>Self-regulating crankcase heater (TCH)</b> 自适应曲轴箱加热器								
	Increasing the energy efficiency and reducing the warm-up time. The thermal regulated crankcase heater reduces the output power once the set temperature is reached. Depending on the working conditions there is up to 30% energy saving compared to the standard heater (BT001) / 与传统加热器相比, 自适应曲轴箱加热器可提高能效并减少预热时间。一旦达到设定温度, 自适应曲轴箱加热器会降低输出功率。节能情况视不同工况而变, 与传统的曲轴箱加热器相比, 最多可节省30%的耗能。(参见技术手册BT001)	○	○	○	○	○	○	○	○
	<b>Maximum discharge temperature sensor (TMAX)</b> 最高排气温度PTC(TMAX)								
	A thermistor probe is monitoring the discharge temperature to be kept below 130°C (BT007) / PTC监控压缩机排气温度, 确保其保持在130°C以下。(参见技术手册BT007)	●	●	●	●	●	●	●	●
	<b>Oil differential pressure switch (ODPS) ATEX certified</b> ATEX认证的油压差开关 (ODPS)								
	Compressors with oil pump are equipped with an oil differential pressure switch set to 0,85 bar which must be connected in series with all other compressors protections (see BT007) 带油泵的压缩机配备了一个油压差开关, 设定在0.85bar的压差, 油压差开关必须与所有其它保护装置串联连接 (BT007)						●	●	●
	<b>Oil charge /</b> 润滑油充注								
	All compressors are charged in the factory with POE (for HFC) or PAG (for HC) before the mechanical and electrical running tests / 在进行机械和电气测试前, 所有压缩机都已在工厂充注了POE油 (用于HFC) 或PAG油 (用于HC) 。	●	●	●	●	●	●	●	●

## Standard and Optional Accessories

### 标配件与选配件

#### MODEL 型号

● STANDARD 标配 | ○ OPTIONAL 选配

HEX11 HEX2 HEX33 HEX35 HEX41 HEX5 HEX6 HEX7

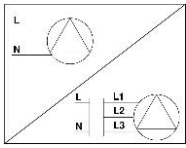

#### Three phase to single phase kit / 三相转单相装置

HEX11 range up to HEX281CC can be assembled with 1ph electric motor instead of the standard 3ph and Dorin provides a kit with the capacitors and the relays (electric data of the 1ph motors at page 9 and 11). Another option is represented by this electronic module, used to connect a 3ph compressor to 1ph power line. The module allows soft start and variable frequency

HEX11系列中HEX281CC及其以下的压缩机机型可配备单相电机代替三相电机，Dorin 都凌为此类电机提供启动和运行电容器和继电器（单相电机的数据在第9页和第11页）。本电子模块代表了另一种选择，即使用这个模块可将标配的三相电机压缩机连接到单相电源。该模块还包含软启动和变频功能。



○

#### Inverter / 变频器

Any model in the HEX range can be equipped with inverter to work at variable speed from 30 Hz until 70 Hz. Each inverter is preset in the factory for an easy installation. Additional info on the compressors working with inverter can be found in the dedicated technical bulletin

HEX系列所有型号均可配置变频器使用，可在30Hz至70Hz之间变频工作。变频器参数在工厂预设置，方便安装使用。有关压缩机变频操作的更多信息，请参阅专门的技术手册。



○

○

○

○

○

○

○

○

#### Capacity control head (CR) ATEX certified / ATEX认证能调头 (CR)

A mechanical capacity control system can be applied on compressors from 4 cylinders and above (BT002) / 4缸及以上的压缩机可配置能调头



○

○

○

○

○

○

#### Unloaded start (US) ATEX certified / ATEX认证的卸载启动 (US)

With a part-winding start system it is seldom used the unloaded start for bypassing the suction with the discharge, reducing significantly the absorbed inrush current (BT009) / 在分线圈启动的系统中，通常使用卸载启动（通过旁通排气到吸气端），来显著降低启动电流。（参见技术手册BT009）

在分线圈启动的系统中，通常使用卸载启动（通过旁通排气到吸气端），来显著降低启动电流。（参见技术手册BT009）

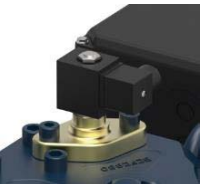

○

○

○

○

○

○

#### Water cooled head (WH) / 水冷缸头 (WU)

Refer to DORIN software to know when this is needed (BT006) / 请查看 DORIN选型软件以了解什么工况下需选用此配件。（参见技术手册BT006）



○

○

○

○

○

○

○

○

#### Suction and discharge service valves / 吸排气阀



●

●

●

●

●

●

●

●

## Oil Charge / Service Valves / Net Weight

### 注油量/吸排气阀/净重

RANGE 系列	MODEL 型号	CYLINDERS 缸数	OIL CHARGE 注油量	SUCTION 吸气	DISCHARGE 排气	NET WEIGHT 净重
		[-]	(liters)	SL [mm]	DL [mm]	[kg]
HEX11	HEX51CS	2	1,0	12s	12s	35
	HEX80CC	2	1,0	12s	12s	36
	HEX80CS	2	1,0	16s	12s	36
	HEX101CC	2	1,0	16s	12s	37
	HEX101CS	2	1,0	16s	12s	37
	HEX151CC	2	1,0	16s	12s	38
	HEX151CS	2	1,0	16s	12s	38
	HEX181CC	2	1,0	16s	12s	39
	HEX181CS	2	1,0	16s	12s	39
	HEX201CC	2	1,0	16s	12s	40
	HEX201CS	2	1,0	18s	16s	40
	HEX221CC	2	1,0	18s	16s	41
	HEX221CS	2	1,0	18s	16s	41
	HEX251CC	2	1,0	18s	16s	41
	HEX251CS	2	1,0	18s	16s	41
	HEX281CC	2	1,0	18s	16s	43
	HEX281SB	2	1,0	18s	16s	44
	HEX281CS	2	1,0	18s	16s	44
HEX2	HEX290CS	2	1,4	22s	16s	54
	HEX300CC	2	1,4	22s	16s	54
	HEX300CS	2	1,4	28s	16s	54
	HEX350CC	2	1,4	28s	16s	54
	HEX350SB	2	1,4	28s	16s	54
	HEX380CC	2	1,4	28s	16s	56
	HEX380SB	2	1,4	28s	16s	56
	HEX390CS	2	1,4	28s	16s	56
HEX392CS	2	1,4	28s	16s	56	
HEX33	HEX355CS	4	1,8	22s	16s	77
	HEX405CC	4	1,8	22s	16s	77
	HEX405CS	4	1,8	28s	16s	78
	HEX505CC	4	1,8	28s	16s	78
	HEX505CS	4	1,8	28s	18s	78
	HEX705CC	4	1,8	28s	18s	78
	HEX705CS	4	1,8	28s	18s	78
HEX755CC	4	1,8	28s	18s	78	
HEX35	HEX551CS	4	2,0	28s	22s	91
	HEX701CC	4	2,0	28s	22s	91
	HEX701CS	4	2,0	28s	22s	91
	HEX751CC	4	2,0	28s	22s	91
	HEX751CS	4	2,0	35s	22s	91
	HEX1002CC	4	2,0	35s	22s	99
	HEX801CS	4	2,0	35s	22s	91
	HEX1003CC	4	2,0	35s	22s	99
	HEX901CS	4	2,0	35s	22s	99
	HEX1151CC	4	2,0	35s	22s	101

RANGE 系列	MODEL 型号	CYLINDERS 缸数	OIL CHARGE 注油量	SUCTION 吸气	DISCHARGE 排气	NET WEIGHT 净重
		[-]	(liters)	SL [mm]	DL [mm]	[kg]
HEX41	HEX851CS	4	2,5	35s	28s	125
	HEX1201CC	4	2,5	35s	28s	130
	HEX1001CS	4	2,5	35s	28s	127
	HEX1501CC	4	2,5	42s	28s	131
	HEX1501CS	4	2,5	35s	28s	127
	HEX2001CC	4	2,5	42s	28s	131
	HEX1601CS	4	2,5	42s	28s	134
	HEX2201CC	4	2,5	42s	28s	136
	HEX2201CS	4	2,5	42s	28s	134
	HEX2401CC	4	2,5	42s	28s	136
HEX5	HEX2000CS	4	3,5	42s	28s	190
	HEX2500CC	4	3,5	54s	28s	185
	HEX2500CS	4	3,5	54s	28s	185
	HEX3000CC	4	3,5	54s	28s	199
	HEX2700CS	4	3,5	54s	35s	200
	HEX3200CC	4	3,5	54s	35s	205
	HEX2900CS	4	3,5	54s	35s	205
	HEX3400CC	4	3,5	54s	35s	205
	HEX3001CS	4	3,5	54s	35s	205
	HEX3501CC	4	3,5	54s	35s	205
HEX6	HEX3000CS	6	3,5	54s	35s	235
	HEX3500CC	6	3,5	54s	35s	246
	HEX3500CS	6	3,5	54s	35s	233
	HEX4000CC	6	3,5	54s	35s	249
	HEX4000CS	6	3,5	54s	42s	244
	HEX4500CC	6	3,5	54s	42s	252
	HEX4500CS	6	3,5	54s	42s	253
	HEX5000CC	6	3,5	54s	42s	253
	HEX5001CS	6	3,5	54s	42s	253
HEX7	HEX5000CS	8	8,5	66s	42s	350
	HEX5500CC	8	8,5	66s	42s	355
	HEX5500CS	8	8,5	80s	42s	350
	HEX6000CC	8	8,5	80s	42s	355
	HEX6000CS	8	8,5	80s	42s	355
	HEX7500CC	8	8,5	80s	42s	357
	HEX7501CS	8	8,5	80s	54s	355
	HEX8001CC	8	8,5	80s	54s	357
	HEX8000CS	8	8,5	80s	54s	360
HEX9000CC	8	8,5	80s	54s	366	

# HEX SERIES

## Electric Motor FLA (Full Load Ampere)

### 电子最大运行电流 (满载电流)

RANGE 系列	MODEL 型号	DISPLACEMENT 排气量		MAX OPERATING CURRENT / 最大工作电流 V / ph / Hz [A]													MAX ABSORBED POWER 最大输入功率	
		50 Hz	60 Hz	220-240 / 1 / 50	208-230 / 1 / 60	220-240 / 3 / 50 265-290 / 3 / 60 D	380-420 / 3 / 50 440-480 / 3 / 60 Y	208-230 / 3 / 60 D	360-400 / 3 / 60 Y	200 / 3 / 50-60 D	380-420 / 3 / 50 440-480 / 3 / 60 PWS	200-240 / 3 / 50 PWS	208-230 / 3 / 60 PWS	360-400 / 3 / 60 PWS	475-525 / 3 / 50 570-630 / 3 / 60	50 Hz [kW]	60 Hz [kW]	
		[m3/h]	[m3/h]															
HEX11	HEX51CS	4,42	5,30	7,5	9,0	3,1	1,8	3,7	2,2	4,3	-	-	-	-	1,4	1,0	1,2	
	HEX80CC	4,42	5,30	7,5	9,0	4,2	2,4	5,0	2,9	5,7	-	-	-	-	1,9	1,3	1,6	
	HEX80CS	5,37	6,44	7,5	9,0	4,2	2,4	5,0	2,9	5,7	-	-	-	-	1,9	1,3	1,6	
	HEX101CC	5,37	6,44	9,0	10,8	5,0	2,9	6,0	3,5	6,9	-	-	-	-	2,3	1,6	1,9	
	HEX101CS	6,71	8,05	9,0	10,8	5,0	2,9	6,0	3,5	6,9	-	-	-	-	2,3	1,6	1,9	
	HEX151CC	6,71	8,05	13,5	16,2	5,9	3,4	7,1	4,1	8,1	-	-	-	-	2,7	2,0	2,4	
	HEX151CS	7,50	9,00	13,5	16,2	5,9	3,4	7,1	4,1	8,1	-	-	-	-	2,7	2,0	2,4	
	HEX181CC	7,50	9,00	15,0	18,0	7,6	4,4	9,1	5,3	10,5	-	-	-	-	3,5	2,6	3,2	
	HEX181CS	9,16	10,99	15,0	18,0	7,6	4,4	9,1	5,3	10,5	-	-	-	-	3,5	2,6	3,2	
	HEX201CC	9,16	10,99	15,0	18,0	10,4	6,0	12,5	7,2	14,4	-	-	-	-	4,8	3,6	4,4	
	HEX201CS	9,88	11,86	15,0	18,0	7,6	4,4	9,1	5,3	10,5	-	-	-	-	3,5	2,6	3,2	
	HEX221CC	9,88	11,86	19,0	23,0	10,4	6,0	12,5	7,2	14,4	-	-	-	-	4,8	3,6	4,4	
	HEX221CS	10,61	12,73	19,0	23,0	10,4	6,0	12,5	7,2	14,4	-	-	-	-	4,8	3,6	4,4	
	HEX251CC	10,61	12,73	19,0	23,0	12,6	7,3	15,1	8,7	17,4	-	-	-	-	5,8	4,2	5,1	
	HEX251CS	11,64	13,97	19,0	23,0	10,4	6,0	12,5	7,2	14,4	-	-	-	-	4,8	3,6	4,4	
	HEX281CC	11,64	13,97	21,0	25,0	12,6	7,3	15,1	8,7	17,4	-	-	-	-	5,8	4,2	5,1	
HEX281SB	13,23	15,88	-	-	10,4	6,0	12,5	7,2	14,4	-	-	-	-	4,8	3,6	4,4		
HEX281CS	13,23	15,88	-	-	12,6	7,3	15,1	8,7	17,4	-	-	-	-	5,8	4,2	5,1		
HEX2	HEX290CS	14,74	17,69	-	-	12,9	7,5	15,5	8,9	17,8	-	-	-	-	6,0	4,4	5,3	
	HEX300CC	14,74	17,69	-	-	16,2	9,4	19,4	11,2	22,5	-	-	-	-	7,5	5,5	6,6	
	HEX300CS	15,94	19,13	-	-	12,9	7,5	15,5	8,9	17,8	-	-	-	-	6,0	4,4	5,3	
	HEX350CC	15,94	19,13	-	-	16,2	9,4	19,4	11,2	22,5	-	-	-	-	7,5	5,5	6,6	
	HEX350SB	17,53	21,04	-	-	12,9	7,5	15,5	8,9	17,8	-	-	-	-	6,0	4,4	5,3	
	HEX380CC	17,53	21,04	-	-	16,2	9,4	19,4	11,2	22,5	-	-	-	-	7,5	5,5	6,6	
	HEX380SB	19,53	23,43	-	-	12,9	7,5	15,5	8,9	17,8	-	-	-	-	6,0	4,4	5,3	
	HEX390CS	19,53	23,43	-	-	16,2	9,4	19,4	11,2	22,5	-	-	-	-	7,5	5,5	6,6	
HEX392CS	23,31	27,97	-	-	19,5	11,3	23,5	13,5	27,0	-	-	-	-	9,0	4,6	5,5		
HEX33	HEX355CS	19,29	23,14	-	-	18,1	10,5	21,5	12,6	25,0	10,5	-	-	-	8,4	6,2	7,4	
	HEX405CC	19,29	23,14	-	-	25,0	14,5	30,0	17,4	34,5	14,5	-	-	-	11,6	8,7	10,5	
	HEX405CS	23,13	27,76	-	-	18,1	10,5	21,5	12,6	25,0	10,5	-	-	-	8,4	6,2	7,4	
	HEX505CC	23,13	27,76	-	-	25,0	14,5	30,0	17,4	34,5	14,5	-	-	-	11,6	8,7	10,5	
	HEX505CS	27,33	32,80	-	-	25,0	14,5	30,0	17,4	34,5	14,5	-	-	-	11,6	8,7	10,5	
	HEX705CC	27,33	32,80	-	-	34,0	19,5	41,0	23,5	47,0	19,5	-	-	-	15,6	11,4	13,7	
	HEX705CS	31,88	38,26	-	-	25,0	14,5	30,0	17,4	34,5	14,5	-	-	-	11,6	8,7	10,5	
	HEX755CC	31,88	38,26	-	-	34,0	19,5	41,0	23,5	47,0	19,5	-	-	-	15,6	11,4	13,7	
HEX35	HEX551CS	27,33	32,80	-	-	25,0	14,5	30,0	17,4	34,5	14,5	-	-	-	11,6	8,7	10,5	
	HEX701CC	27,33	32,80	-	-	34,0	19,5	41,0	23,5	47,0	19,5	-	-	-	15,6	11,4	13,7	
	HEX701CS	31,88	38,26	-	-	25,0	14,5	30,0	17,4	34,5	14,5	-	-	-	11,6	8,7	10,5	
	HEX751CC	31,88	38,26	-	-	34,0	19,5	41,0	23,5	47,0	19,5	-	-	-	15,6	11,4	13,7	
	HEX751CS	38,06	45,67	-	-	34,0	19,5	41,0	23,5	47,0	19,5	-	-	-	15,6	11,4	13,7	
	HEX1002CC	38,06	45,67	-	-	40,0	23,0	48,0	27,5	55,0	23,0	-	-	-	18,4	13,8	16,6	
	HEX801CS	43,73	52,48	-	-	34,0	19,5	41,0	23,5	47,0	19,5	-	-	-	15,6	11,4	13,7	
	HEX1003CC	43,73	52,48	-	-	40,0	23,0	48,0	27,5	55,0	23,0	-	-	-	18,4	13,8	16,6	
	HEX901CS	47,80	57,36	-	-	40,0	23,0	48,0	27,5	55,0	23,0	-	-	-	18,4	13,8	16,6	
HEX1151CC	47,80	57,36	-	-	43,0	25,0	52,0	30,0	60,0	25,0	-	-	-	20,0	15,3	18,4		

# HEX SERIES

## Electric Motor FLA (Full Load Ampere)

### 电子最大运行电流 (满载电流)

RANGE 系列	MODEL 型号	DISPLACEMENT 排气量		MAX OPERATING CURRENT / 最大工作电流 V / ph / Hz [A]													MAX ABSORBED POWER 最大输入功率	
		50 Hz	60 Hz	220-240 / 1 / 50	208-230 / 1 / 60	220-240 / 3 / 50 265-290 / 3 / 60 D	380-420 / 3 / 50 440-480 / 3 / 60 Y	208-230 / 3 / 60 D	360-400 / 3 / 60 Y	200 / 3 / 50-60 D	380-420 / 3 / 50 440-480 / 3 / 60 PWS	200-240 / 3 / 50 PWS	208-230 / 3 / 60 PWS	360-400 / 3 / 60 PWS	475-525 / 3 / 50 570-630 / 3 / 60	50 Hz [kW]	60 Hz [kW]	
		[m <sup>3</sup> /h]	[m <sup>3</sup> /h]															
HEX41	HEX851CS	42,81	51,38	-	-	34,5	20,0	41,5	24,0	-	20,0	34,5	41,5	24,0	16,0	11,7	14,1	
	HEX1201CC	42,81	51,38	-	-	48,5	28,0	58,0	33,5	-	28,0	48,5	58,0	33,5	22,5	16,8	20,2	
	HEX1001CS	48,82	58,58	-	-	41,5	24,0	50,0	29,0	-	24,0	41,5	50,0	29,0	19,2	14,5	17,4	
	HEX1501CC	48,82	58,58	-	-	59,0	34,0	71,0	41,0	-	34,0	59,0	71,0	41,0	27,0	19,5	23,4	
	HEX1501CS	56,87	68,25	-	-	48,5	28,0	58,0	33,5	-	28,0	48,5	58,0	33,5	22,5	16,8	20,2	
	HEX2001CC	56,87	68,25	-	-	66,0	38,0	79,0	45,5	-	38,0	66,0	79,0	45,5	30,5	22,7	27,2	
	HEX1601CS	63,76	76,51	-	-	59,0	34,0	71,0	41,0	-	34,0	59,0	71,0	41,0	27,0	19,5	23,4	
	HEX2201CC	63,76	76,51	-	-	78,0	45,0	93,0	54,0	-	45,0	78,0	93,0	54,0	36,0	26,6	31,9	
	HEX2201CS	70,84	85,01	-	-	66,0	38,0	79,0	45,5	-	38,0	66,0	79,0	45,5	30,5	22,7	27,2	
HEX2401CC	70,84	85,01	-	-	78,0	45,0	93,0	54,0	-	45,0	78,0	93,0	54,0	36,0	26,6	31,9		
HEX5	HEX2000CS	75,83	91,00	-	-	66,0	38,0	79,0	45,5	-	38,0	66,0	79,0	45,5	30,5	22,7	27,2	
	HEX2500CC	75,83	91,00	-	-	83,0	48,0	100,0	58,0	-	48,0	83,0	99,6	57,6	38,5	28,5	34,2	
	HEX2500CS	85,01	102,02	-	-	78,0	45,0	93,0	54,0	-	45,0	78,0	93,0	54,0	36,0	26,6	31,9	
	HEX3000CC	85,01	102,02	-	-	97,0	56,0	116,0	67,0	-	56,0	97,0	116,0	67,0	45,0	33,4	40,1	
	HEX2700CS	92,25	110,69	-	-	83,0	48,0	100,0	58,0	-	48,0	83,0	99,6	57,6	38,5	28,5	34,2	
	HEX3200CC	92,25	110,69	-	-	104,0	60,0	125,0	72,0	-	60,0	104,0	125,0	72,0	48,0	35,2	42,3	
	HEX2900CS	102,35	122,82	-	-	97,0	56,0	116,0	67,0	-	56,0	97,0	116,0	67,0	45,0	33,4	40,1	
	HEX3400CC	102,35	122,82	-	-	104,0	60,0	125,0	72,0	-	60,0	104,0	125,0	72,0	48,0	35,2	42,3	
	HEX3001CS	112,97	135,57	-	-	97,0	56,0	116,0	67,0	-	56,0	97,0	116,0	67,0	45,0	33,4	40,1	
HEX3501CC	112,97	135,57	-	-	104,0	60,0	125,0	72,0	-	60,0	104,0	125,0	72,0	48,0	35,2	42,3		
HEX6	HEX3000CS	113,74	136,49	-	-	103,9	60,0	124,7	72,0	-	60,0	103,9	124,7	72,0	48,0	35,9	43,1	
	HEX3500CC	113,74	136,49	-	-	114,3	66,0	137,2	79,2	-	66,0	114,3	137,2	79,2	52,8	39,3	47,1	
	HEX3500CS	127,52	153,02	-	-	103,9	60,0	124,7	72,0	-	60,0	103,9	124,7	72,0	48,0	35,9	43,1	
	HEX4000CC	127,52	153,02	-	-	129,9	75,0	155,9	90,0	-	75,0	129,9	155,9	90,0	60,0	45,5	54,6	
	HEX4000CS	138,37	166,04	-	-	114,3	66,0	137,2	79,2	-	66,0	114,3	137,2	79,2	52,8	39,3	47,1	
	HEX4500CC	138,37	166,04	-	-	145,5	84,0	174,6	100,8	-	84,0	145,5	174,6	100,8	67,2	51,1	61,4	
	HEX4500CS	153,52	184,22	-	-	129,9	75,0	155,9	90,0	-	75,0	129,9	155,9	90,0	60,0	45,5	54,6	
	HEX5000CC	153,52	184,22	-	-	161,1	93,0	193,3	111,6	-	93,0	161,1	193,3	111,6	74,4	56,6	67,9	
	HEX5001CS	169,46	203,35	-	-	161,1	93,0	193,3	111,6	-	93,0	161,1	193,3	111,6	74,4	56,6	67,9	
HEX7	HEX5000CS	164,30	197,16	-	-	155,9	90,0	187,1	108,0	-	90,0	155,9	187,1	108,0	72,0	52,9	63,4	
	HEX5500CC	164,30	197,16	-	-	181,9	105,0	218,2	126,0	-	105,0	181,9	218,2	126,0	84,0	60,2	72,2	
	HEX5500CS	184,19	221,03	-	-	181,9	105,0	218,2	126,0	-	105,0	181,9	218,2	126,0	84,0	60,2	72,2	
	HEX6000CC	184,19	221,03	-	-	207,8	120,0	249,4	144,0	-	120,0	207,8	249,4	144,0	96,0	69,1	82,9	
	HEX6000CS	199,86	239,83	-	-	181,9	105,0	218,2	126,0	-	105,0	181,9	218,2	126,0	84,0	60,2	72,2	
	HEX7500CC	199,86	239,83	-	-	256,3	148,0	307,6	177,6	-	148,0	256,3	307,6	177,6	118,4	85,8	103,0	
	HEX7501CS	221,75	266,10	-	-	207,8	120,0	249,4	144,0	-	120,0	207,8	249,4	144,0	96,0	69,1	82,9	
	HEX8001CC	221,75	266,10	-	-	256,3	148,0	307,6	177,6	-	148,0	256,3	307,6	177,6	118,4	85,8	103,0	
	HEX8000CS	244,78	293,74	-	-	207,8	120,0	249,4	144,0	-	120,0	207,8	249,4	144,0	96,0	69,1	82,9	
HEX9000CC	244,78	293,74	-	-	256,3	148,0	307,6	177,6	-	148,0	256,3	307,6	177,6	118,4	85,8	103,0		

Standard version of the motor / contact our technical service for operating conditions not present in the catalog  
非标电机咨询技术部门

Electric Motor LRA (Locked Rotor Ampere)

锁定转子电流LRA(堵转电流)

RANGE 系列	MODEL 型号	DISPLACEMENT 排气量		LOCKED ROTOR CURRENT / 锁定转子电流 V / ph / Hz [A]											
		50 Hz	60 Hz	220-240 / 1 / 50	208-230 / 1 / 60	220-240 / 3 / 50 265-290 / 3 / 60 D	380-420 / 3 / 50 440-480 / 3 / 60 Y	208-230 / 3 / 60 D	360-400 / 3 / 60 Y	200 / 3 / 50-60 D	380-420 / 3 / 50 440-480 / 3 / 60 PWS	200-240 / 3 / 50 PWS	208-230 / 3 / 60 PWS	360-400 / 3 / 60 PWS	475-525 / 3 / 50 570-630 / 3 / 60
		[m3/h]	[m3/h]												
HEX11	HEX51CS	4,42	5,30	31,0	37,0	16,0	9,0	19,0	11,0	19,0	-	-	-	-	7,0
	HEX80CC	4,42	5,30	31,0	37,0	19,0	11,0	23,0	13,0	23,0	-	-	-	-	9,0
	HEX80CS	5,37	6,44	31,0	37,0	19,0	11,0	23,0	13,0	23,0	-	-	-	-	9,0
	HEX101CC	5,37	6,44	47,0	56,0	24,0	14,0	29,0	17,0	29,0	-	-	-	-	11,0
	HEX101CS	6,71	8,05	47,0	56,0	24,0	14,0	29,0	17,0	29,0	-	-	-	-	11,0
	HEX151CC	6,71	8,05	73,0	88,0	27,0	16,0	33,0	19,0	33,0	-	-	-	-	12,0
	HEX151CS	7,50	9,00	73,0	88,0	27,0	16,0	33,0	19,0	33,0	-	-	-	-	12,0
	HEX181CC	7,50	9,00	81,0	97,0	35,0	20,0	42,0	24,0	42,0	-	-	-	-	16,0
	HEX181CS	9,16	10,99	81,0	97,0	35,0	20,0	42,0	24,0	42,0	-	-	-	-	16,0
	HEX201CC	9,16	10,99	81,0	97,0	42,0	25,0	51,0	30,0	51,0	-	-	-	-	20,0
	HEX201CS	9,88	11,86	81,0	97,0	35,0	20,0	42,0	24,0	42,0	-	-	-	-	16,0
	HEX221CC	9,88	11,86	91,0	109,0	42,0	25,0	51,0	30,0	51,0	-	-	-	-	20,0
	HEX221CS	10,61	12,73	91,0	109,0	42,0	25,0	51,0	30,0	51,0	-	-	-	-	20,0
	HEX251CC	10,61	12,73	91,0	109,0	55,0	32,0	66,0	39,0	66,0	-	-	-	-	26,0
	HEX251CS	11,64	13,97	91,0	109,0	42,0	25,0	51,0	30,0	51,0	-	-	-	-	20,0
	HEX281CC	11,64	13,97	91,0	109,0	55,0	32,0	66,0	39,0	66,0	-	-	-	-	26,0
HEX281SB	13,23	15,88	-	-	42,0	25,0	51,0	30,0	51,0	-	-	-	-	20,0	
HEX281CS	13,23	15,88	-	-	55,0	32,0	66,0	39,0	66,0	-	-	-	-	26,0	
HEX2	HEX290CS	14,74	17,69	-	-	59,0	34,0	71,0	41,0	71,0	-	-	-	-	27,0
	HEX300CC	14,74	17,69	-	-	76,0	44,0	91,0	52,0	91,0	-	-	-	-	35,0
	HEX300CS	15,94	19,13	-	-	59,0	34,0	71,0	41,0	71,0	-	-	-	-	27,0
	HEX350CC	15,94	19,13	-	-	76,0	44,0	91,0	52,0	91,0	-	-	-	-	35,0
	HEX350SB	17,53	21,04	-	-	59,0	34,0	71,0	41,0	71,0	-	-	-	-	27,0
	HEX380CC	17,53	21,04	-	-	76,0	44,0	91,0	52,0	91,0	-	-	-	-	35,0
	HEX380SB	19,53	23,43	-	-	59,0	34,0	71,0	41,0	71,0	-	-	-	-	27,0
	HEX390CS	19,53	23,43	-	-	76,0	44,0	91,0	52,0	91,0	-	-	-	-	35,0
HEX392CS	23,31	27,97	-	-	93,0	54,0	112,0	65,0	112,0	-	-	-	-	43,0	
HEX33	HEX355CS	19,29	23,14	-	-	92,0	53,0	110,0	64,0	110,0	53,0	-	-	-	43,0
	HEX405CC	19,29	23,14	-	-	109,0	63,0	131,0	76,0	131,0	63,0	-	-	-	50,0
	HEX405CS	23,13	27,76	-	-	92,0	53,0	110,0	64,0	110,0	53,0	-	-	-	43,0
	HEX505CC	23,13	27,76	-	-	109,0	63,0	131,0	76,0	131,0	63,0	-	-	-	50,0
	HEX505CS	27,33	32,80	-	-	109,0	63,0	131,0	76,0	131,0	63,0	-	-	-	50,0
	HEX705CC	27,33	32,80	-	-	149,0	86,0	179,0	103,0	179,0	86,0	-	-	-	69,0
	HEX705CS	31,88	38,26	-	-	109,0	63,0	131,0	76,0	131,0	63,0	-	-	-	50,0
	HEX755CC	31,88	38,26	-	-	149,0	86,0	179,0	103,0	179,0	86,0	-	-	-	69,0
HEX35	HEX551CS	27,33	32,80	-	-	109,0	63,0	131,0	76,0	131,0	63,0	-	-	-	50,0
	HEX701CC	27,33	32,80	-	-	149,0	86,0	179,0	103,0	179,0	86,0	-	-	-	69,0
	HEX701CS	31,88	38,26	-	-	109,0	63,0	131,0	76,0	131,0	63,0	-	-	-	50,0
	HEX751CC	31,88	38,26	-	-	149,0	86,0	179,0	103,0	179,0	86,0	-	-	-	69,0
	HEX751CS	38,06	45,67	-	-	149,0	86,0	179,0	103,0	179,0	86,0	-	-	-	69,0
	HEX1002CC	38,06	45,67	-	-	159,0	92,0	191,0	110,0	191,0	92,0	-	-	-	74,0
	HEX801CS	43,73	52,48	-	-	149,0	86,0	179,0	103,0	179,0	86,0	-	-	-	69,0
	HEX1003CC	43,73	52,48	-	-	159,0	92,0	191,0	110,0	191,0	92,0	-	-	-	74,0
	HEX901CS	47,80	57,36	-	-	159,0	92,0	191,0	110,0	220,0	92,0	-	-	-	74,0
HEX1151CC	47,80	57,36	-	-	189,0	109,0	227,0	131,0	261,0	109,0	-	-	-	87,0	

## Electric Motor LRA (Locked Rotor Ampere)

### 锁定转子电流LRA(堵转电流)

RANGE 系列	MODEL 型号	DISPLACEMENT 排气量		LOCKED ROTOR CURRENT / 锁定转子电流 V / ph / Hz [A]											
		50 Hz	60 Hz	220-240 / 1 / 50	208-230 / 1 / 60	220-240 / 3 / 50 265-290 / 3 / 60 D	380-420 / 3 / 50 440-480 / 3 / 60 Y	208-230 / 3 / 60 D	360-400 / 3 / 60 Y	200 / 3 / 50-60 D	380-420 / 3 / 50 440-480 / 3 / 60 PWS	200-240 / 3 / 50 PWS	208-230 / 3 / 60 PWS	360-400 / 3 / 60 PWS	475-525 / 3 / 50 570-630 / 3 / 60
		[m3/h]	[m3/h]												
HEX41	HEX851CS	42,81	51,38	-	-	181,0	105,0	217,0	126,0	-	105,0	181,0	217,0	126,0	84,0
	HEX1201CC	42,81	51,38	-	-	233,0	135,0	280,0	162,0	-	135,0	233,0	280,0	162,0	108,0
	HEX1001CS	48,82	58,58	-	-	188,0	109,0	226,0	130,0	-	109,0	188,0	226,0	130,0	87,0
	HEX1501CC	48,82	58,58	-	-	295,0	171,0	354,0	205,0	-	171,0	295,0	354,0	205,0	136,0
	HEX1501CS	56,87	68,25	-	-	233,0	135,0	280,0	162,0	-	135,0	233,0	280,0	162,0	108,0
	HEX2001CC	56,87	68,25	-	-	306,0	177,0	367,0	212,0	-	177,0	306,0	367,0	212,0	142,0
	HEX1601CS	63,76	76,51	-	-	295,0	171,0	354,0	205,0	-	171,0	295,0	354,0	205,0	136,0
	HEX2201CC	63,76	76,51	-	-	351,0	203,0	421,0	244,0	-	203,0	351,0	421,0	244,0	162,0
	HEX2201CS	70,84	85,01	-	-	306,0	177,0	367,0	212,0	-	177,0	306,0	367,0	212,0	142,0
	HEX2401CC	70,84	85,01	-	-	351,0	203,0	421,0	244,0	-	203,0	351,0	421,0	244,0	162,0
HEX5	HEX2000CS	75,83	91,00	-	-	306,0	177,0	367,0	212,0	-	177,0	306,0	367,0	212,0	142,0
	HEX2500CC	75,83	91,00	-	-	351,0	203,0	421,0	244,0	-	203,0	351,0	421,0	244,0	162,0
	HEX2500CS	85,01	102,02	-	-	351,0	203,0	421,0	244,0	-	203,0	351,0	421,0	244,0	162,0
	HEX3000CC	85,01	102,02	-	-	424,0	245,0	509,0	294,0	-	245,0	424,0	509,0	294,0	196,0
	HEX2700CS	92,25	110,69	-	-	351,0	203,0	421,0	244,0	-	203,0	351,0	421,0	244,0	162,0
	HEX3200CC	92,25	110,69	-	-	450,0	260,0	540,0	312,0	-	260,0	450,0	540,0	312,0	208,0
	HEX2900CS	102,35	122,82	-	-	424,0	245,0	509,0	294,0	-	245,0	424,0	509,0	294,0	196,0
	HEX3400CC	102,35	122,82	-	-	450,0	260,0	540,0	312,0	-	260,0	450,0	540,0	312,0	208,0
	HEX3001CS	112,97	135,57	-	-	424,0	245,0	509,0	294,0	-	245,0	424,0	509,0	294,0	196,0
	HEX3501CC	112,97	135,57	-	-	450,0	260,0	540,0	312,0	-	260,0	450,0	540,0	312,0	208,0
HEX6	HEX3000CS	113,74	136,49	-	-	424,0	245,0	509,0	294,0	-	245,0	424,0	509,0	294,0	196,0
	HEX3500CC	113,74	136,49	-	-	450,0	260,0	540,0	312,0	-	260,0	450,0	540,0	312,0	208,0
	HEX3500CS	127,52	153,02	-	-	424,0	245,0	509,0	294,0	-	245,0	424,0	509,0	294,0	196,0
	HEX4000CC	127,52	153,02	-	-	502,0	290,0	602,0	348,0	-	290,0	502,0	602,0	348,0	232,0
	HEX4000CS	138,37	166,04	-	-	450,0	260,0	540,0	312,0	-	260,0	450,0	540,0	312,0	208,0
	HEX4500CC	138,37	166,04	-	-	559,0	323,0	671,0	388,0	-	323,0	559,0	671,0	388,0	258,0
	HEX4500CS	153,52	184,22	-	-	502,0	290,0	602,0	348,0	-	290,0	502,0	602,0	348,0	232,0
	HEX5000CC	153,52	184,22	-	-	619,0	358,0	743,0	430,0	-	358,0	619,0	743,0	430,0	286,0
	HEX5001CS	169,46	203,35	-	-	619,0	358,0	743,0	430,0	-	358,0	619,0	743,0	430,0	286,0
HEX7	HEX5000CS	164,30	197,16	-	-	636,0	367,0	763,0	440,0	-	367,0	636,0	763,0	440,0	294,0
	HEX5500CC	164,30	197,16	-	-	788,0	455,0	946,0	546,0	-	455,0	788,0	946,0	546,0	364,0
	HEX5500CS	184,19	221,03	-	-	788,0	455,0	946,0	546,0	-	455,0	788,0	946,0	546,0	364,0
	HEX6000CC	184,19	221,03	-	-	942,0	544,0	1131,0	653,0	-	544,0	942,0	1131,0	653,0	435,0
	HEX6000CS	199,86	239,83	-	-	788,0	455,0	946,0	546,0	-	455,0	788,0	946,0	546,0	364,0
	HEX7500CC	199,86	239,83	-	-	1012,0	584,0	1214,0	701,0	-	584,0	1012,0	1214,0	701,0	467,0
	HEX7501CS	221,75	266,10	-	-	942,0	544,0	1131,0	653,0	-	544,0	942,0	1131,0	653,0	435,0
	HEX8001CC	221,75	266,10	-	-	1012,0	584,0	1214,0	701,0	-	584,0	1012,0	1214,0	701,0	467,0
	HEX8000CS	244,78	293,74	-	-	942,0	544,0	1131,0	653,0	-	544,0	942,0	1131,0	653,0	435,0
	HEX9000CC	244,78	293,74	-	-	1012,0	584,0	1214,0	701,0	-	584,0	1012,0	1214,0	701,0	467,0

# HEX SERIES

## Noise Level

### 噪音水平

RANGE 系列	MODEL 型号	DISPLACEMENT 排气量		SOUND PRESSURE (FREE FIELD) 声压 (分贝)						SOUND POWER 声功率		
				1,8 m			5 m			ISO9614-1 grade 2		
		50 Hz		60 Hz		Te / Tc [°C]		Te / Tc [°C]		Te / Tc [°C]		
		[m³/h]		[dB(A)]								
HEX11	HEX51CS	4,42	5,30			47,8			38,9			63,9
	HEX80CC	4,42	5,30	46,5			37,6			62,6		
	HEX80CS	5,37	6,44			48,6			39,7			64,7
	HEX101CC	5,37	6,44	48,3			39,4			64,4		
	HEX101CS	6,71	8,05			49,8			40,9			65,9
	HEX151CC	6,71	8,05	49,2			40,3			65,3		
	HEX151CS	7,50	9,00			50,1			41,2			66,2
	HEX181CC	7,50	9,00	49,6			40,7			65,7		
	HEX181CS	9,16	10,99			50,7			41,8			66,8
	HEX201CC	9,16	10,99	49,8			40,9			65,9		
	HEX201CS	9,88	11,86			51,2			42,3			67,3
	HEX221CC	9,88	11,86	50,0			41,1			66,1		
	HEX221CS	10,61	12,73			51,8			42,9			67,9
	HEX251CC	10,61	12,73	51,9			43,0			68,0		
	HEX251CS	11,64	13,97		49,8	51,8		40,9	42,9		65,9	67,9
HEX281CC	11,64	13,97	54,8	53,4	51,8	45,9	44,5	42,9	70,9	69,5	67,9	
HEX281SB	13,23	15,88		53,4	51,8		44,5	42,9		69,5	67,9	
HEX281CS	13,23	15,88		53,4	51,8		44,5	42,9		69,5	67,9	
HEX2	HEX290CS	14,74	17,69			51,9			43,0			68,0
	HEX300CC	14,74	17,69		51,4	51,9		42,5	43,0			68,0
	HEX300CS	15,94	19,13	50,9	51,4		42,0	42,5		67,0	67,5	
	HEX350CC	15,94	19,13	51,4	51,9		42,5	43,0		67,5	68,0	
	HEX350SB	17,53	21,04	51,4	51,9		42,5	43,0		67,5	68,0	
	HEX380CC	17,53	21,04			52,4			43,5			68,5
	HEX380SB	19,53	23,43	52,9	52,4		44,0	43,5		69,0	68,5	
	HEX390CS	19,53	23,43			53,4			44,5			69,5
HEX392CS	23,31	27,97		53,9	54,4		45,0	45,5		70,0	70,5	
HEX33	HEX355CS	19,29	23,14		54,4	55,4		45,5	46,5		70,5	71,5
	HEX405CC	19,29	23,14	55,4	56,4		46,5	47,5		71,5	72,5	
	HEX405CS	23,13	27,76		55,4	56,9		46,5	48,0		71,5	73,0
	HEX505CC	23,13	27,76	55,9	56,9		47,0	48,0		72,0	73,0	
	HEX505CS	27,33	32,80		57,9	58,4		49,0	49,5		74,0	74,5
	HEX705CC	27,33	32,80		58,4	58,9		49,5	50,0		74,5	75,0
	HEX705CS	31,88	38,26	57,9	58,4	58,9	49,0	49,5	50,0	74,0	74,5	75,0
HEX755CC	31,88	38,26		58,9	59,4		50,0	50,5		75,0	75,5	
HEX35	HEX551CS	27,33	32,80		57,9	58,4		49,0	49,5		74,0	74,5
	HEX701CC	27,33	32,80	57,9	58,4	58,9	49,0	49,5	50,0	74,0	74,5	75,0
	HEX701CS	31,88	38,26		58,4	58,9		49,5	50,0		74,5	75,0
	HEX751CC	31,88	38,26	58,4	58,9	59,4	49,5	50,0	50,5	74,5	75,0	75,5
	HEX751CS	38,06	45,67		58,9	59,4		50,0	50,5		75,0	75,5
	HEX1002CC	38,06	45,67	58,4	58,9	59,9	49,5	50,0	51,0	74,5	75,0	76,0
	HEX801CS	43,73	52,48		58,9	59,4		50,0	50,5		75,0	75,5
	HEX1003CC	43,73	52,48	58,9	59,4	59,9	50,0	50,5	51,0	75,0	75,5	76,0
	HEX901CS	47,80	57,36		59,4	59,9		50,5	51,0		75,5	76,0
HEX1151CC	47,80	57,36	58,9	59,9	60,4	50,5	51,0	51,5	75,5	76,0	76,5	

# HEX SERIES

## Noise Level

### 噪音水平

RANGE 系列	MODEL 型号	DISPLACEMENT 排气量		SOUND PRESSURE (FREE FIELD) 声压 (分贝)						SOUND POWER 声功率		
				1,8 m			5 m			ISO9614-1 grade 2		
		50 Hz		60 Hz		Te / Tc [°C]		Te / Tc [°C]		Te / Tc [°C]		
		[m³/h]		[dB(A)]								
HEX41	HEX851CS	42,81	51,38		58,9	60,4		50,0	51,5		75,0	76,5
	HEX1201CC	42,81	51,38	58,9	58,9	60,4	50,0	50,0	51,5	75,0	75,0	76,5
	HEX1001CS	48,82	58,58		60,9	61,4		52,0	52,5		77,0	77,5
	HEX1501CC	48,82	58,58	60,4	60,9	61,4	51,5	52,0	52,5	76,5	77,0	77,5
	HEX1501CS	56,87	68,25		61,9	62,6		53,0	53,7		78,0	78,7
	HEX2001CC	56,87	68,25	61,4	61,9	62,6	52,5	53,0	53,7	77,5	78,0	78,7
	HEX1601CS	63,76	76,51		62,9	63,4		54,0	54,5		79,0	79,5
	HEX2201CC	63,76	76,51	62,4	62,9	63,4	53,5	54,0	54,5	78,5	79,0	79,5
	HEX2201CS	70,84	76,51		62,9	63,4		54,0	54,5		79,0	79,5
	HEX2401CC	70,84	85,01	62,4	62,9	63,4	53,5	54,0	54,5	78,5	79,0	79,5
HEX5	HEX2000CS	75,83	91,00		61,4	61,9		52,5	53,0		77,5	78,0
	HEX2500CC	75,83	91,00	60,9	61,4	61,9	52,0	52,5	53,0	77,0	77,5	78,0
	HEX2500CS	85,01	102,02		62,4	62,9		53,5	54,0		78,5	79,0
	HEX3000CC	85,01	102,02	61,9	62,4	62,9	53,0	53,5	54,0	78,0	78,5	79,0
	HEX2700CS	92,25	110,69		63,4	63,9		54,5	55,0		79,5	80,0
	HEX3200CC	92,25	110,69	62,9	63,4	63,9	54,0	54,5	55,0	79,0	79,5	80,0
	HEX2900CS	102,35	122,82		64,4	64,9		55,5	56,0		80,5	81,0
	HEX3400CC	102,35	122,82	63,9	64,4	64,9	55,0	55,5	56,0	80,0	80,5	81,0
	HEX3001CS	112,97	135,57		64,9	65,4		56,0	56,5		81,0	81,5
	HEX3501CC	112,97	135,57	64,4	64,9	65,4	55,5	56,0	56,5	80,5	81,0	81,5
HEX6	HEX3000CS	113,74	136,49		65,4	65,9		56,5	57,0		81,5	82,0
	HEX3500CC	113,74	136,49	64,9	65,4	65,9	56,0	56,5	57,0	81,0	81,5	82,0
	HEX3500CS	127,52	153,02		65,9	66,4		57,0	57,5		82,0	82,5
	HEX4000CC	127,52	153,02	65,4	65,9	66,4	56,5	57,0	57,5	81,5	82,0	82,5
	HEX4000CS	138,37	166,04		66,4	66,9		57,5	58,0		82,5	83,0
	HEX4500CC	138,37	166,04	65,9	66,4	66,9	57,0	57,5	58,0	82,0	82,5	83,0
	HEX4500CS	153,52	184,22		66,5	67,0		57,6	58,1		82,6	83,1
	HEX5000CC	153,52	184,22	66,5	67,0	67,5	57,6	58,1	58,6	82,6	83,1	83,6
	HEX5001CS	169,46	203,55		67,0	67,5		58,1	58,6		83,1	83,6
HEX7	HEX5000CS	164,30	197,16		66,9	67,4		58,0	58,5		83,0	83,5
	HEX5500CC	164,30	197,16	66,4	66,9	67,4	57,5	58,0	58,5	82,5	83,0	83,5
	HEX5500CS	184,19	221,03		67,1	67,6		58,2	58,7		83,2	83,7
	HEX6000CC	184,19	221,03	66,6	67,1	67,6	57,7	58,2	58,7	82,7	83,2	83,7
	HEX6000CS	199,86	239,83		67,3	67,8		58,4	58,9		83,4	83,9
	HEX7500CC	199,86	239,83	66,8	67,3	67,8	57,9	58,4	58,9	82,9	83,4	83,9
	HEX7501CS	221,75	266,10		67,4	67,9		58,5	59,0		83,5	84,0
	HEX8001CC	221,75	266,10	66,9	67,4	67,9	58,0	58,5	59,0	83,0	83,5	84,0
	HEX8000CS	244,78	293,74		67,5	68,0		58,6	59,1		83,6	84,1
	HEX9000CC	244,78	293,74	67,0	67,5	68,0	58,1	58,6	59,1	83,1	83,6	84,1

Application Envelope

应用包络线

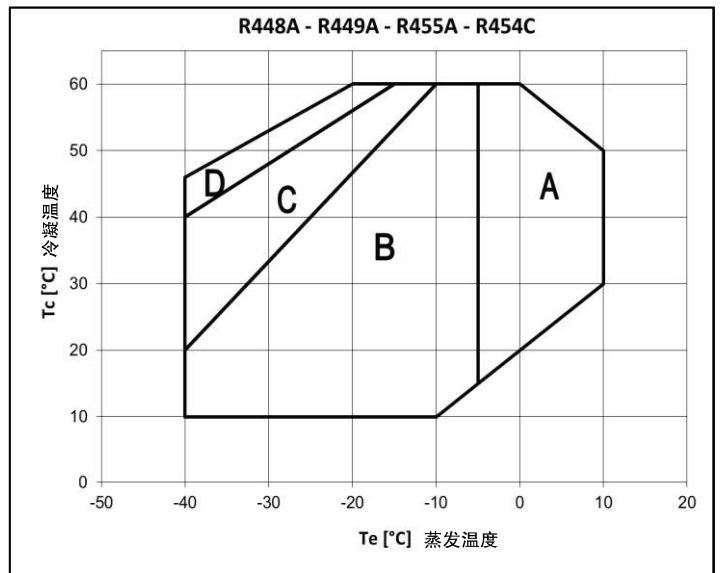
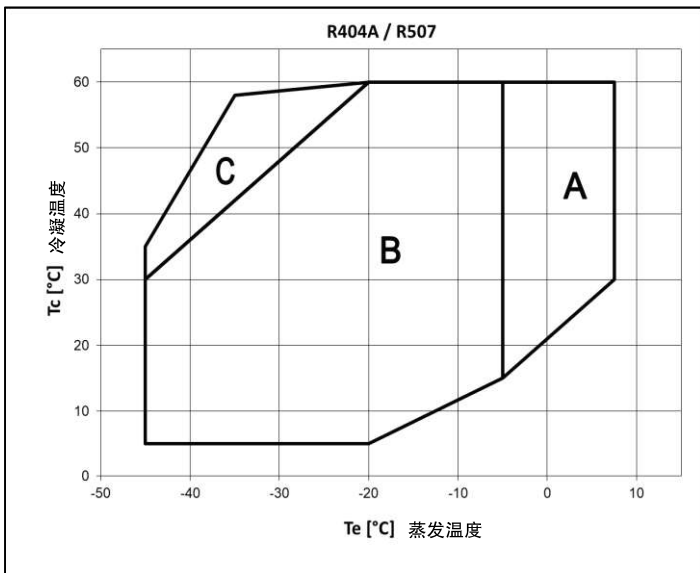
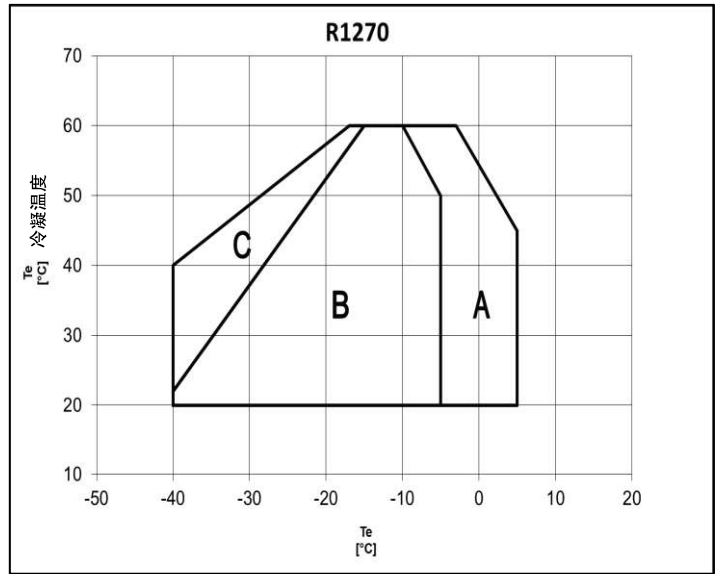
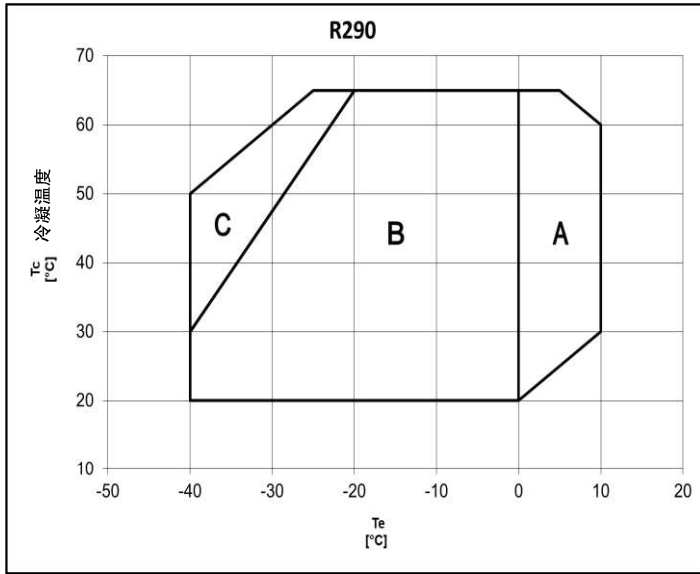

The application envelope changes depending on the compressor model and is available for every model and for every refrigerant in the DORIN web software  
应用包络线随压缩机型号变化并且可以在都凌选型软件查到

<b>A</b>	«CC» MODELS ONLY / 仅限«CC»型号
<b>B</b>	«CC» AND «CS» MODELS / «CC»和«CS»型号可用
<b>C</b>	«CC» AND «CS» MODELS with head cooling fan or max superheating 20 K / «CC» 和 «CS» 型号可用，需带缸头风机或过热度 ≤ 20 K
<b>D</b>	«CC» AND «CS» MODELS with head cooling fan and max superheating 20 K / «CC» 和 «CS»型号可用，需带缸头风机且过热度 ≤ 20 K

## Application Envelope

### 应用包络线

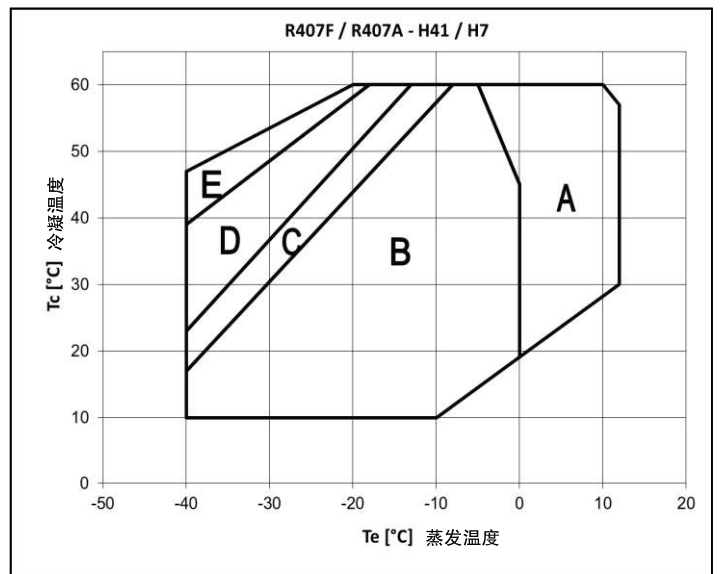
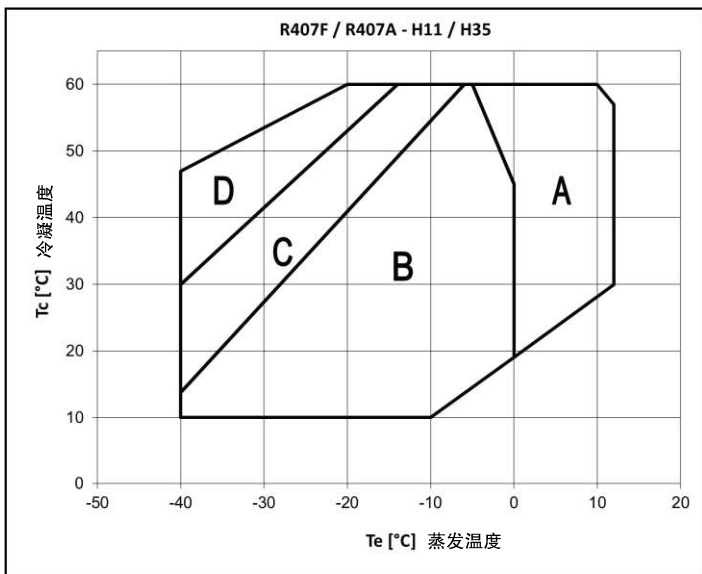
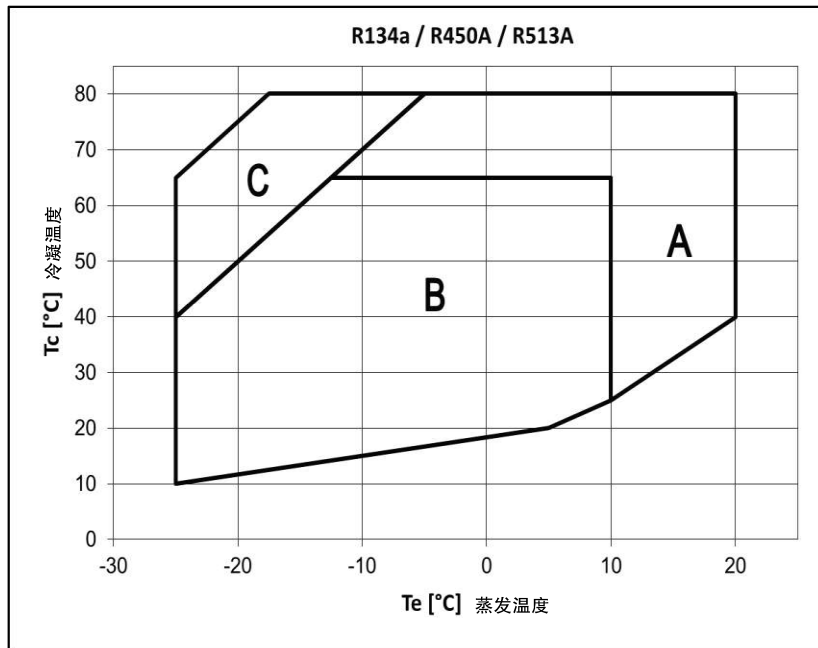

The application envelope changes depending on the compressor model and is available for every model and for every refrigerant in the DORIN web software  
应用包络线随压缩机型号变化并且可以在都凌选型软件查到

A	«CC» MODELS ONLY / 仅限«CC»型号
B	«CC» AND «CS» MODELS / «CC»和«CS»型号可用
C	«CC» AND «CS» MODELS with head cooling fan or max superheating 20 K / «CC» 和 «CS» 型号带缸头风机或过热度 ≤ 20 K
D	«CC» AND «CS» MODELS with head cooling fan and max superheating 30 K (head cooling fan and DTC if superheating is > 30 K) / «CC» 和 «CS» 型号可用, 带缸头风机且最大过热度为 30 K(如果过热度 > 30 K, 则须配置缸头风机和 DTC)
E	«CC» AND «CS» MODELS with head cooling fan and max superheating 20 K (head cooling fan and DTC if superheating is > 20 K) / «CC»和 «CS» 型号可用, 带缸头风机且最大过热度为 20 K ( 如果过热度 > 20 K, 则须配置缸头风机和 DTC )

Technical Drawings

外形尺寸

HEX11

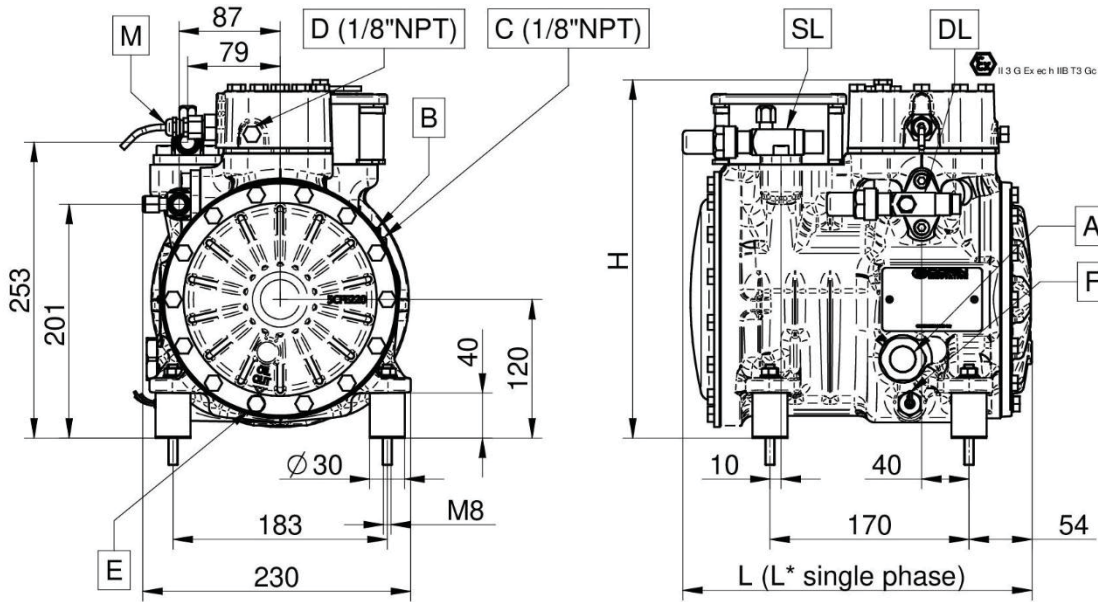

MODEL 型号	L	L*	H
	[mm]	[mm]	[mm]
HEX51CS	295	321	307
HEX80CC	295	321	307
HEX80CS	298	321	307
HEX101CC	305	328	307
HEX101CS	305	328	307
HEX151CC	305	343	307
HEX151CS	305	343	307
HEX181CC	321	354	307
HEX181CS	325	363	312
HEX201CC	325	363	312
HEX201CS	325	363	312
HEX221CC	325	363	312
HEX221CS	325	363	312
HEX251CC	340	363	312
HEX251CS	325	363	315
HEX281CC	340	363	315
HEX281SB	325	---	315
HEX281CS	340	---	315

HEX2

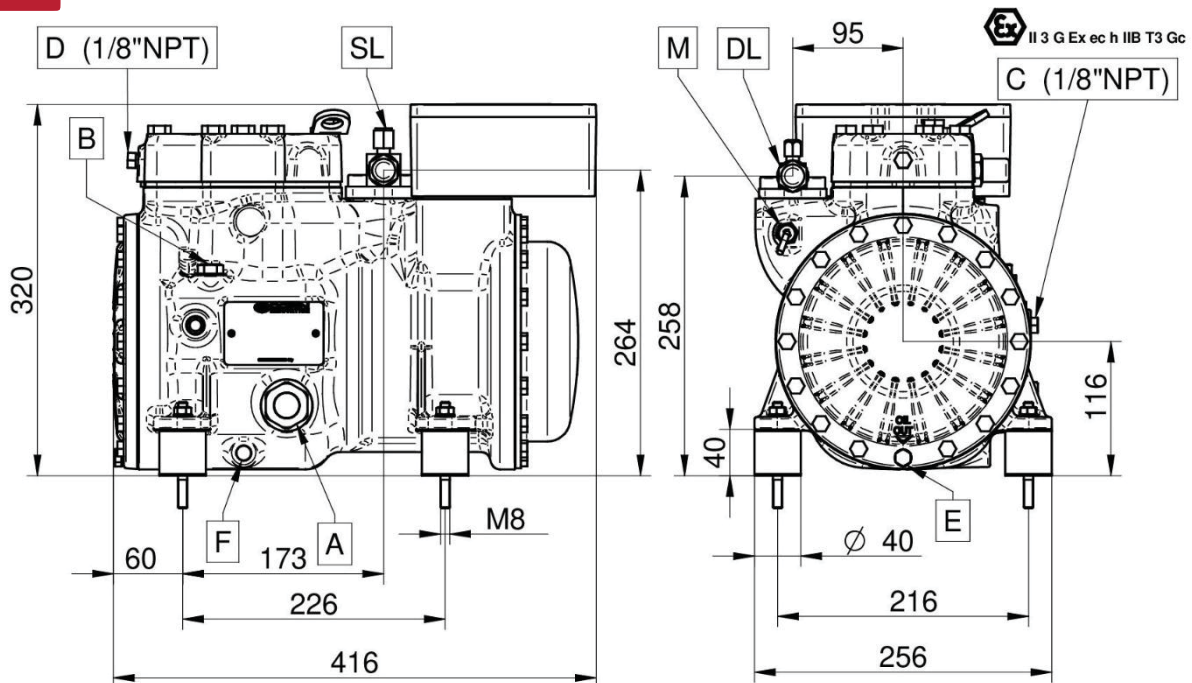

- A - Oil sight glass - 油视镜
- B - Oil charge plug - 注油塞
- C - Low pressure tap - 低压旋塞
- D - High pressure tap - 高压旋塞
- E - Oil drain plug - 排油塞
- F - Crankcase heater - 曲轴箱加热器

- M - Maximum discharge temperature sensor - 最高排气温度传感器
- DL - Discharge service valve - 排气阀
- SL - Suction service valve - 吸气阀

## Technical Drawings

### 外形尺寸

#### HEX33

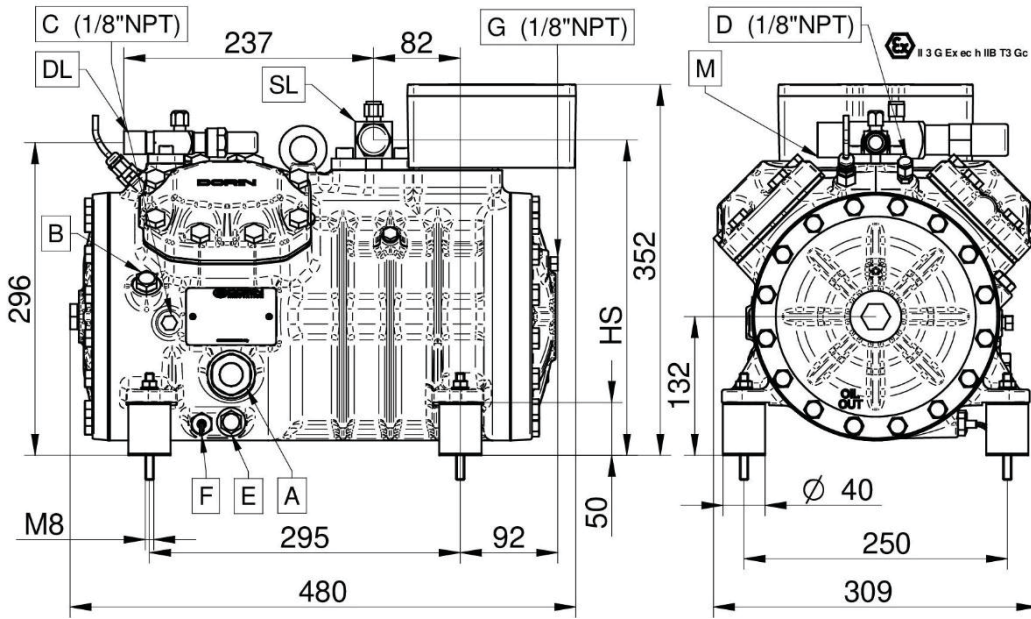

MODEL 型号	HS
	[mm]
HEX355CS	296
HEX405CC	296
HEX405CS	299
HEX505CC	299
HEX505CS	299
HEX705CC	299
HEX705CS	299
HEX755CC	299

#### HEX35

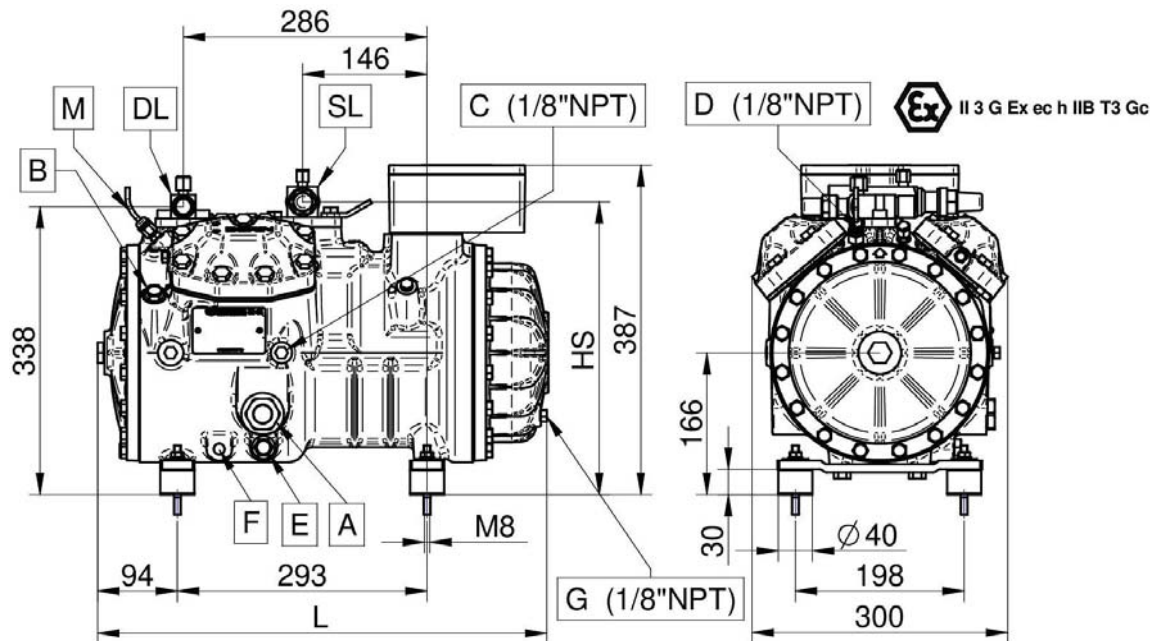

MODEL 型号	L	HS
	[mm]	[mm]
HEX551CS	502	340
HEX701CC	502	340
HEX701CS	502	340
HEX751CC	502	340
HEX751CS	502	340
HEX1002CC	530	344
HEX801CS	502	340
HEX1003CC	530	344
HEX901CS	530	344
HEX1151CC	530	344

- A - Oil sight glass - 油视镜
- B - Oil charge plug - 注油塞
- C - Low pressure tap - 低压旋塞
- D - High pressure tap - 高压旋塞
- E - Oil drain plug - 排油塞
- F - Crankcase heater - 曲轴箱加热器

- G - Oil return - 回油
- M - Maximum discharge temperature sensor - 最高排气温度传感器
- DL - Discharge service valve - 排气阀
- SL - Suction service valve - 吸气阀

Technical Drawings

外形尺寸

HEX41

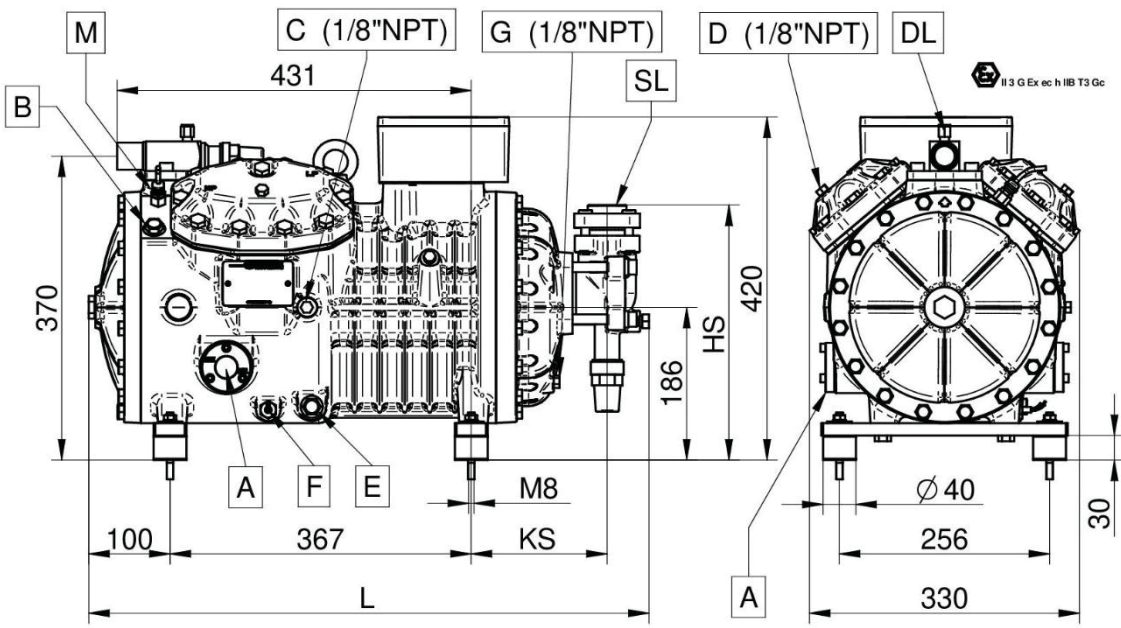

MODEL 型号	L	KS	HS
	[mm]	[mm]	[mm]
HEX851CS	650	140	257
HEX1201CC	650	140	257
HEX1001CS	650	140	257
HEX1501CC	680	166	310
HEX1501CS	650	140	257
HEX2001CC	680	166	310
HEX1601CS	680	166	310
HEX2201CC	680	166	310
HEX2201CS	680	166	310
HEX2401CC	680	166	310

HEX5

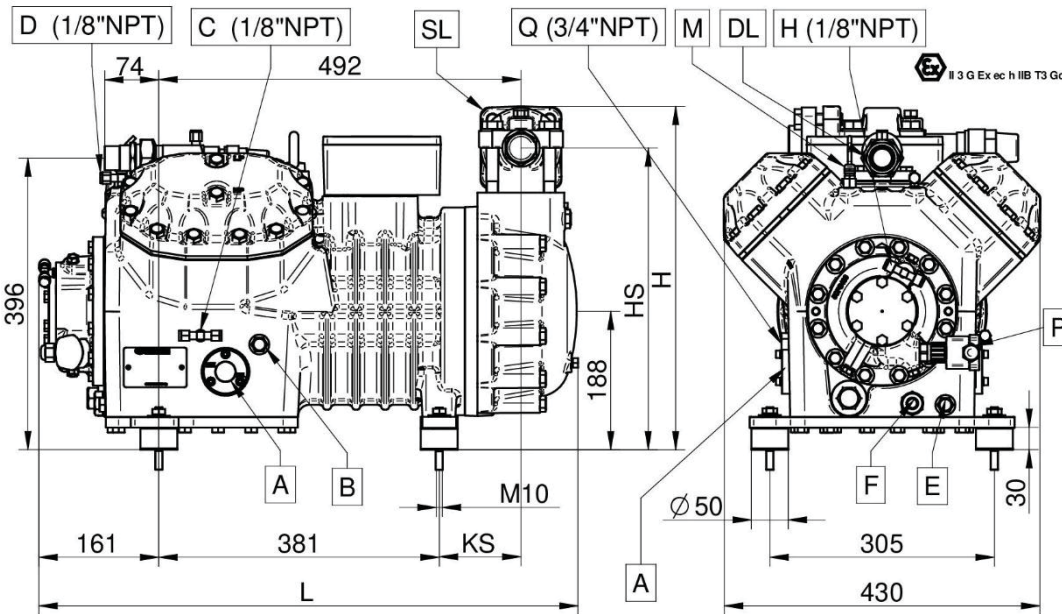

MODEL 型号	L	H	KS	HS
	[mm]	[mm]	[mm]	[mm]
HEX2000CS	710	443	86	392
HEX2500CC	732	466	111	410
HEX2500CS	712	466	91	410
HEX3000CC	732	466	111	410
HEX2700CS	712	466	91	410
HEX3200CC	732	466	111	410
HEX2900CS	712	466	91	410
HEX3400CC	732	466	111	410
HEX3001CS	712	466	91	410
HEX3501CC	732	466	111	410

- A - Oil sight glass - 油视镜
- B - Oil charge plug - 注油塞
- C - Low pressure tap - 低压旋塞
- D - High pressure tap - 高压旋塞
- E - Oil drain plug - 排油塞
- F - Crankcase heater - 曲轴箱加热器

- G - Oil return - 回油
- H - Oil pressure tap - 油压旋塞
- M - Maximum discharge temperature sensor - 最高排气温度传感器
- P - Oil pressure switch - 油压差开关
- Q - Gas equalization - 气体平衡
- DL - Discharge service valve - 排气阀
- SL - Suction service valve - 吸气阀

## Technical Drawings

### 外形尺寸

#### HEX6

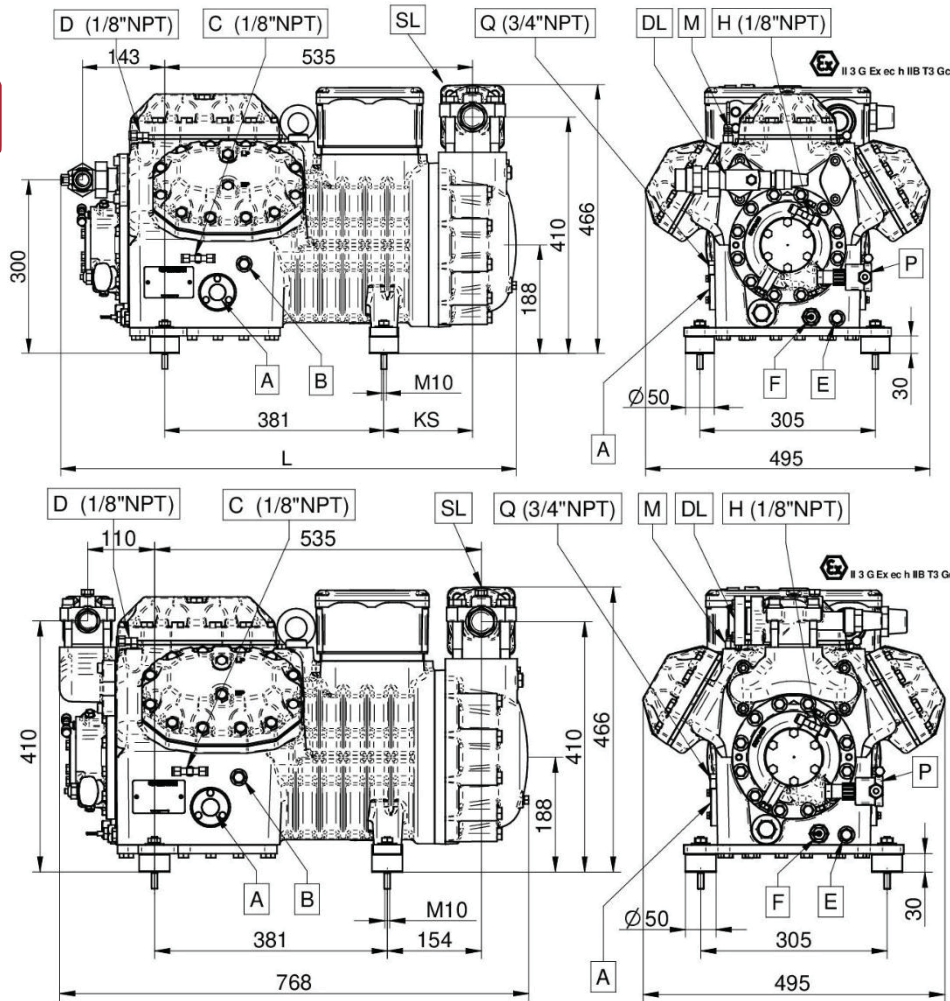

MODEL 型号	L	KS
	[mm]	[mm]
HEX3000CS	773	134
HEX3500CC	793	154
HEX3500CS	773	134
HEX4000CC	793	154

#### HEX7

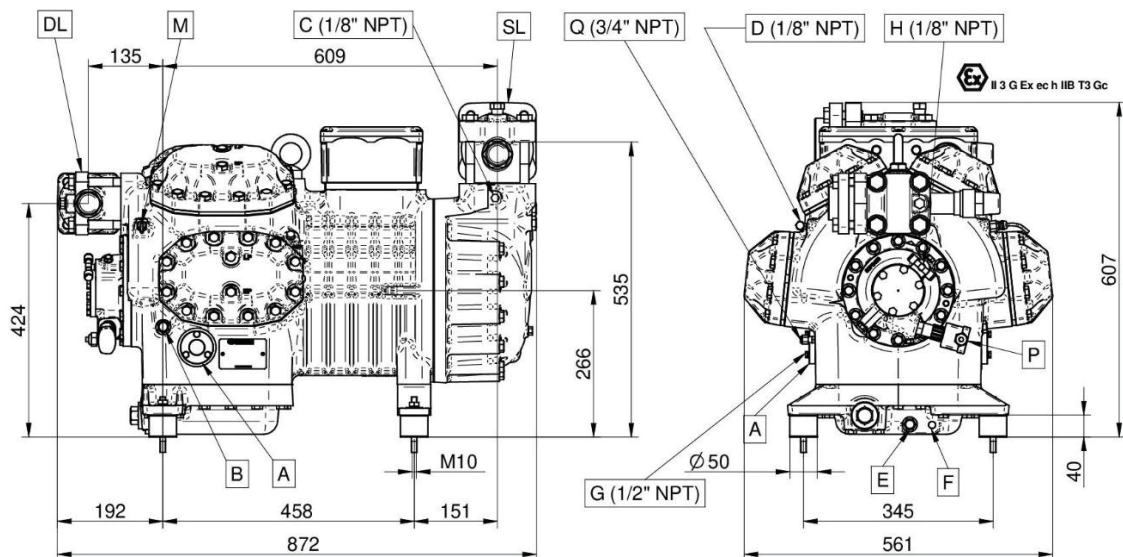

- A - Oil sight glass - 油视镜
- B - Oil charge plug - 注油塞
- C - Low pressure tap - 低压旋塞
- D - High pressure tap - 高压旋塞
- E - Oil drain plug - 排油塞
- F - Crankcase heater - 曲轴箱加热器
- G - Oil return - 回油
- H - Oil pressure tap - 油压旋塞
- M - Maximum discharge temperature sensor - 最高排气温度传感器
- P - Oil pressure switch - 油压差开关
- Q - Gas equalization - 气体平衡
- DL - Discharge service valve - 排气阀
- SL - Suction service valve - 吸气阀







#### **DORIN WEB SOFTWARE**

Open the camera app on your device and point it at the QR code to scan it. Make sure that all the four corners of the QR code are in view. A pop-up notification will appear on your screen, tap the notifications to launch the code.

Dorin都凌在线选型软件  
扫描二维码，即可在线选型



OFFICINE MARIO DORIN S.p.A.  
Via Aretina 388, 50061 Compiobbi - Florence, Italy Tel.  
+39 055 62321 1 - Fax +39 055 62321 380

[dorin@dorin.com](mailto:dorin@dorin.com)  
[www.dorin.com](http://www.dorin.com)

**全国统一服务电话：400-021-9890**